

How to

register the caster/camber angle

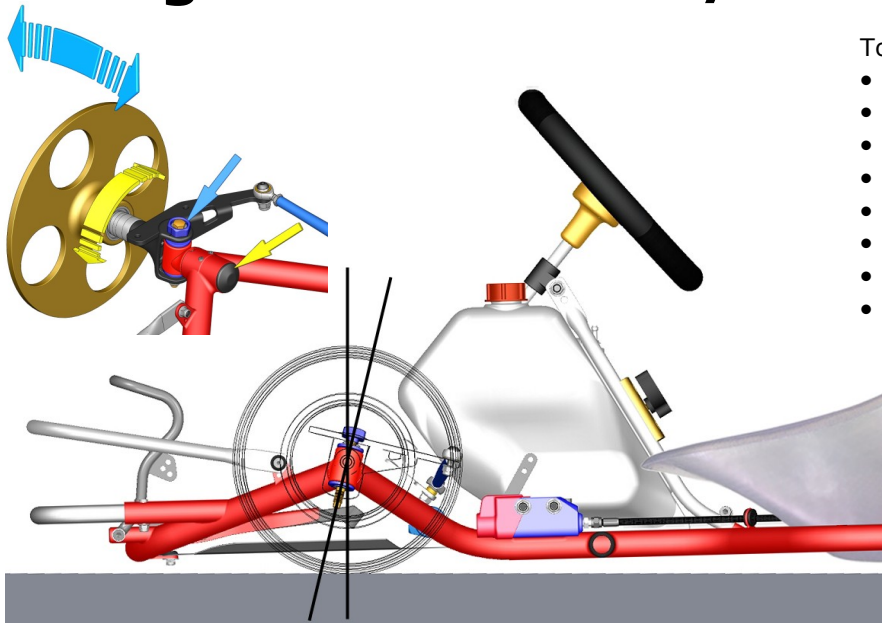

Tools needed

- 22mm box wrench
- 3mm allen wrench
- Digital caster-angle gauge
- 13mm box wrench
- 17mm wrench
- 25mm wrench
- Torque wrench
- Alignment disc

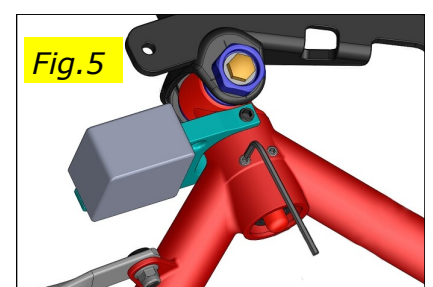
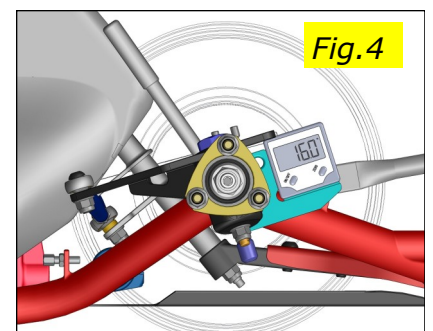
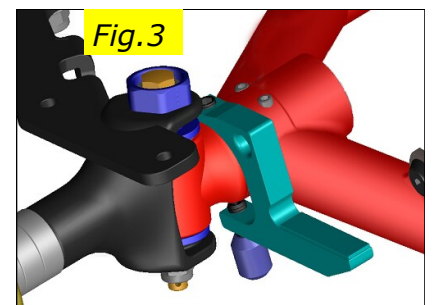
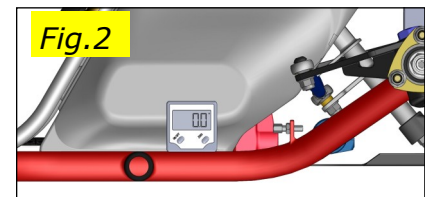
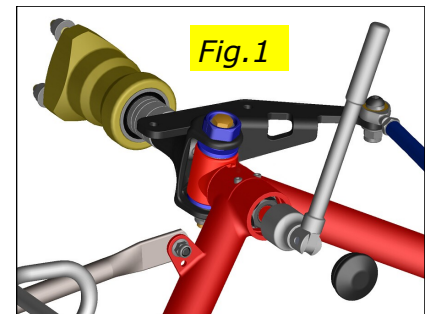

Caster angle

1. Remove the rubber cap. (Fig.1)
2. Loosen the M14 nut using a 22mm box wrench.
3. Continue turns the nut counterclock-wise until the caster-regulator breaks off an engagement.
4. Turn the nut clock-wise to cancel lateral play.
5. *Set the Digital caster-angle gauge on the frame. Turn on and press the ZERO to set the gauge to 0.0 degrees which calibrates the reference surface. (Fig.2)
6. Set the adapter to upper and lower knock-pin. The adapter must be parallel to the frame. (Fig.3)
7. Set the Digital caster-angle gauge on the adapter. Current **caster-angle appear on the display.(Fig.4)
8. Loosen one of two M6 set screws. If you want to increase the caster angle, loosen the front side set screw. If you want to decrease the caster angle, loosen the rear side set screw. (Fig.5)
9. Turn clock-wise another set screw. Then the caster-regulator begins to move.
10. The display will read **caster-angle.
11. Turn clock-wise the set screw which is loosen before until the screw has contacted the caster-regulator surface.
12. Tighten the M14 nut to 55N•m
13. Tighten the two set screws to 2.5N•m
14. Install the rubber cap.
15. Check toe angle.

Example : The LCD display show 16 degrees. (Fig.6)



* After the calibration, The display must remain on the same side(right or left) at every misurement.

** This is relative caster angle to calibrate on the frame. Real caster-angle (the reference surface is the ground.) is variable depending on the front & rear axle height and also depending on the tyres that you are using.

Camber angle

(measure distance with alignment disc)

1. Set the alignment discs.
2. Measure distance of two discs at top and bottom of the disc.
3. Loosen the king-pin with a 13mm box wrench and a 17mm wrench.
4. Turn the eccentric cam with a 25mm wrench. (Fig.7)

Turn symbol "I" to outside	Negative camber
Turn symbol "I" to inside	Positive camber

5. Tighten the king-pin to 35N•m
6. Repeat step 2.

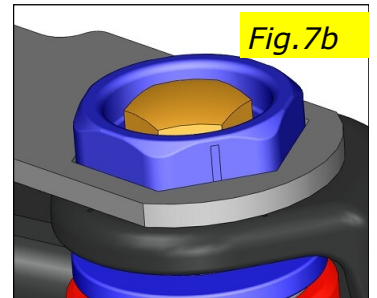
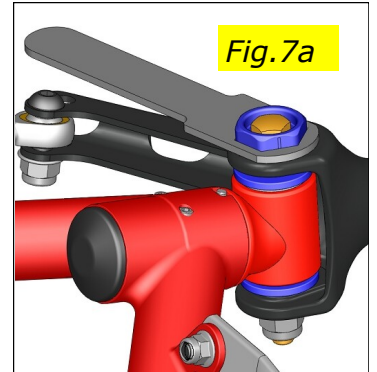

Camber angle

(measure angle with Digital caster-angle gauge)

1. Set the Digital caster-angle gauge on the rear axle. (Fig.8)
2. Turn on and press the ZERO to set the gauge to 0.0 degrees which calibrates the reference surface.
3. Set the Digital caster-angle gauge on the spindle of the stub-axle. Current camber-angle appears on the display. (Fig.9/10)
4. Loosen the king-pin with a 13mm box wrench and a 17mm wrench.
5. Turn the eccentric cam with a 25mm wrench.

Turn symbol "I" to outside	Negative camber
Turn symbol "I" to inside	Positive camber

6. The display will read camber-angle.
7. Tighten the king-pin to 35N•m



Digital caster-angle gauge & adapter

